

# HUAHENG

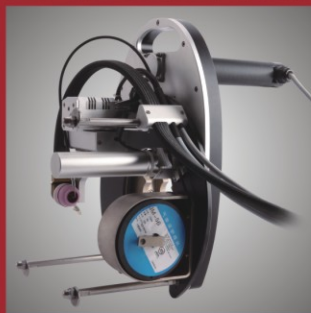
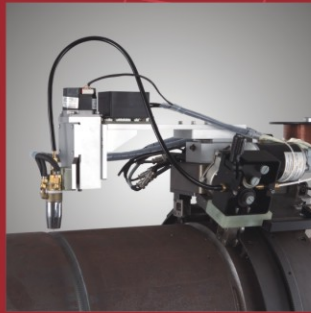
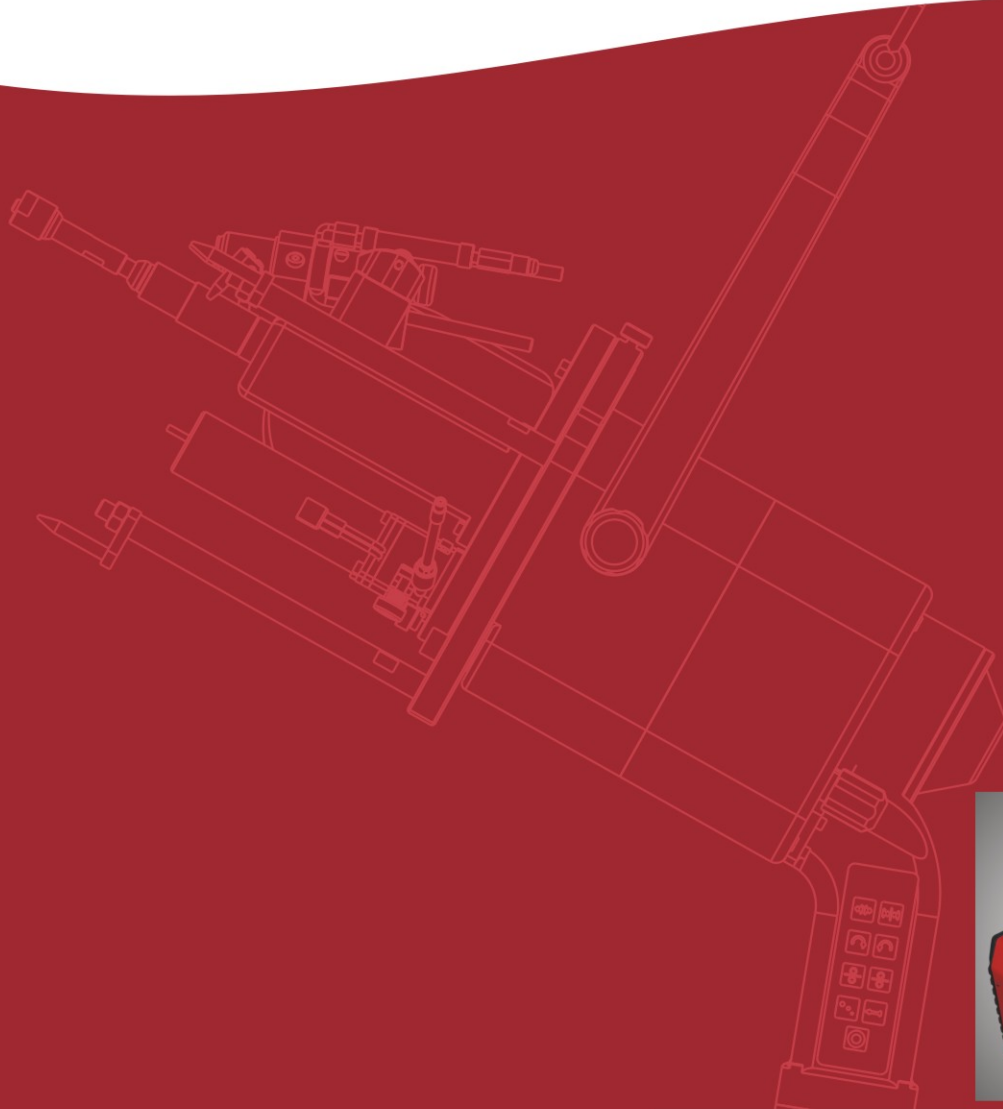

## ORBITAL Welding System

HUAHENG WELDING CO., LTD.

# GTX53

## Hydraulic Hose Automatic Welding System

### Brief Introduction

This system is specially designed for tube to flange TIG welding. It could do single position welding or orbital welding, joint or angle welding, with fusion, wire feeding or wire feeding after self-fusion. It could be placed vertical or horizontal.

Support equipment: i-Arc400 Programmable Orbital Welding Power Source.

Application: Special tube to tube and tube to flange in locomotive, engineering machinery.

### Features

- Pneumatic clamping design, convenient and efficient, precisely positioning to ensure the work-piece stable fixed on the platform;
- Quick and convenient positioning, no wire wrapping required before welding, reduce preparation time;
- Optional to choose with/without wire feeding;
- Water circuit cooling torch for long time working.

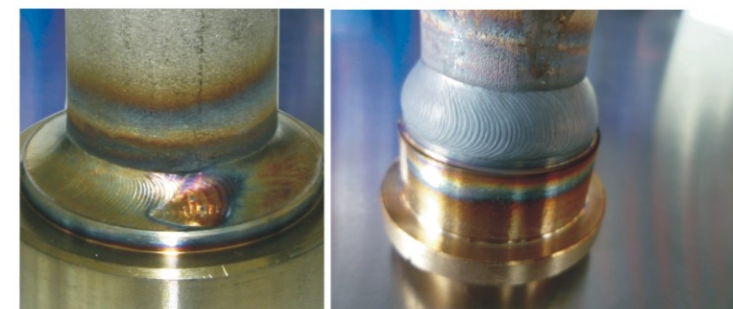
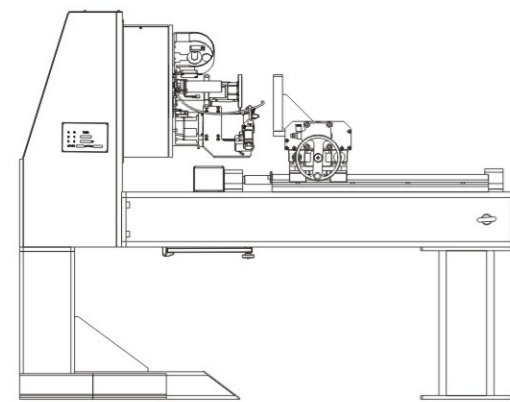

### Technical Specification

Material	Carbon steel, stainless steel
Tube OD (mm)	Φ17~Φ76
Tungsten diameter (mm)	Φ2.4、Φ3.2
Rotation speed (rpm)	0.1~3.29
Torch angle	0° ~45°
Protective gas	Ar
Cooling	Water
Cooling flow (ml/min)	≥600
OSC width (mm)	40
AVC height (mm)	40
Wire diameter (mm)	Φ1.0 (standard)
Max wire feeding speed (mm/min)	1800
Weight (kg)	290
Dimension (mm)	700 × 640 × 1760



# HUAHENG

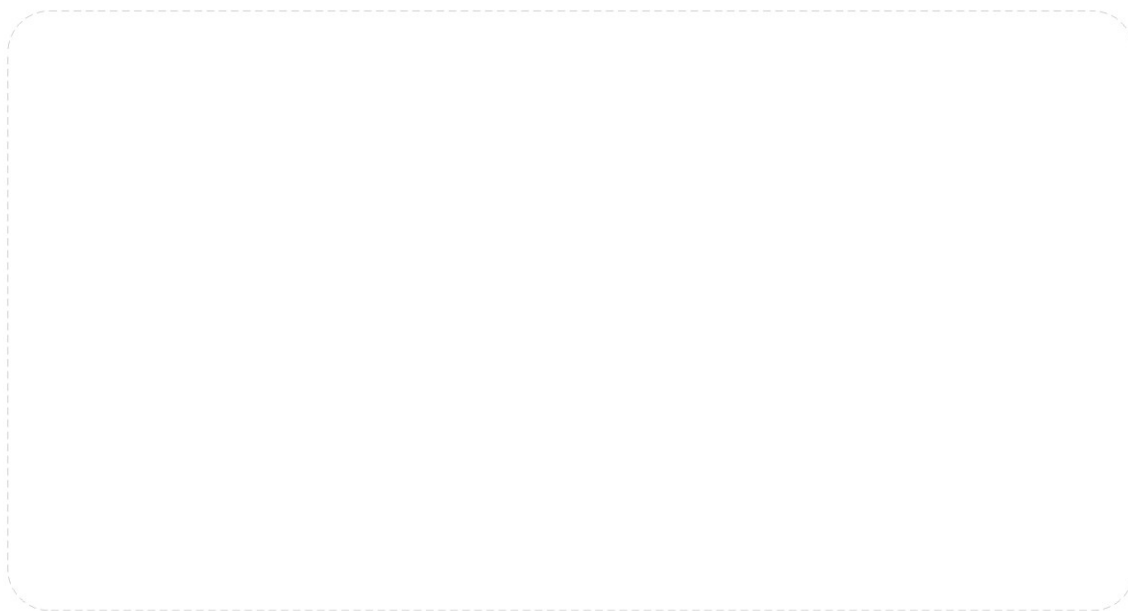

**HUAHENG**  
HUAHENG WELDING CO., LTD.

Add : No.1588 Boshi Road,Kunshan,Jiangsu,P.R.China. PC: 215347  
Tel : +86(0)512-81866666 Fax : +86(0)512-57328188  
[www.huahengweld.com](http://www.huahengweld.com) E-mail : [info@huahengweld.com](mailto:info@huahengweld.com)